

For applications requiring a larger, heavy duty screen. With components such as steel ball bearings, a nylon bushing on the pin end and the exclusive Camlok® roller system the Miralyte Model 'C' provides smooth operation and reliable, lasting performance. May be wall or ceiling mounted. Sizes to 365 x 365cm (12' x 12').

Application

Typical applications include:

- Educational establishments
- Training rooms
- Conference Rooms
- Licensed premises/clubs

General Dimensions

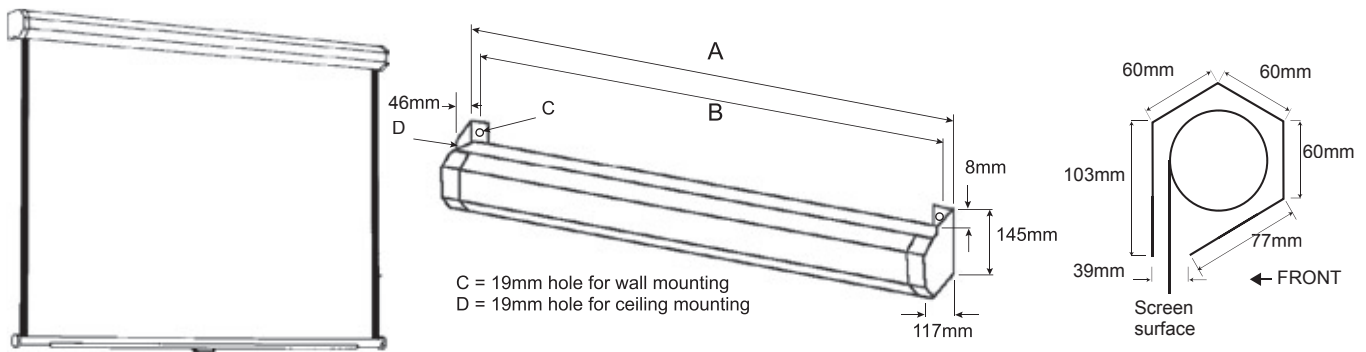

Surface Size	A - Overall Case Length	B - Between Hanger Eyes	Approx Shipping Weight
274 x 274cm (9' x 9')	283cm (9' 3 1/4")	279cm (9' 1 3/4")	26.31kg (58lb)
305 x 244cm (10' x 8')	313cm (10' 3 1/4")	309cm (10' 1 3/4")	28.12kg (62lb)
305 x 305cm (10' x 10')	313cm (10' 3 1/4")	309cm (10' 1 3/4")	29.03kg (64lb)
365 x 274cm (12' x 9')	374cm (12' 3 1/4")	370cm (12' 1 3/4")	31.30kg (69lb)
365 x 365cm (12' x 12')	374cm (12' 3 1/4")	370cm (12' 1 3/4")	32.66kg (72lb)

Screen sizes in excess of 305cm (10' x 10') will have a horizontal seam.

General Detail

Construction

- 22 gauge embossed steel case with flat back design for flush wall fitting and powder coated steel end caps
- Steel inner plates to support roller and provide added case strength
- Off white baked enamel finish
- Extruded aluminium saddle with plate steel pull attached to slat
- Slat ends protected by heavy duty plastic caps
- Metal bumper stops, added with sponge rubber, built into case to prevent slat wedging inside case

Mounting

- Built in fittings for direct wall or ceiling fixing
- Extension brackets for wall fixing - WEB 6 / WEB 23 (15cm - 6" fixed and 58cm - 23" adjustable extension respectively).

Screen Roller System

- 7.5cm (3") diameter ball bearing rigid steel spring roller for smooth operation
- Exclusive Camlok® Roller System prevents surface being accidentally pulled off roller

Surface Options

- Matt White only
- Black masking borders

Operation

- Manual, pull down
- Locks at intervals accommodating various picture formats